

unidirectional motor - series XV

XV-1U

SAE AA TYPE MOTOR
 ø50.8 FLANGE - PARALLEL SHAFT

X 1 U 25 62 B B B A

Series	X	series XV
Group	1	group 1
Category	U	unidirectional motor
Displacement	25	3.8
Flange	62	Ø50.8 SAE AA right rotation
Shaft	B	CI002 - Parallel ø12.7 - key thk. 3.2 (SAE AA)
Body	IN	inlet - 3/8" GAS
	OUT	outlet - 3/8" GAS
Cover	A	standard



XU168

Technical data table

TYPE	Displacement cm3/rev	Max. Pressure		CODE	
		P1 bar	P3 bar	Left rotation	Right rotation
XV-1U/0.9	0,91	240	280	X 1 U 16 61 B B B A	X 1 U 16 62 B B B A
XV-1U/1.2	1,17	250	290	X 1 U 17 61 B B B A	X 1 U 17 62 B B B A
XV-1U/1.7	1,56	250	290	X 1 U 18 61 B B B A	X 1 U 18 62 B B B A
XV-1U/2.2	2,08	250	290	X 1 U 20 61 B B B A	X 1 U 20 62 B B B A
XV-1U/2.6	2,60	250	300	X 1 U 21 61 B B B A	X 1 U 21 62 B B B A
XV-1U/3.2	3,12	250	300	X 1 U 23 61 B B B A	X 1 U 23 62 B B B A
XV-1U/3.8	3,64	250	300	X 1 U 25 61 B B B A	X 1 U 25 62 B B B A
XV-1U/4.3	4,16	250	300	X 1 U 27 61 B B B A	X 1 U 27 62 B B B A
XV-1U/4.9	4,94	250	300	X 1 U 29 61 B B B A	X 1 U 29 62 B B B A
XV-1U/5.9	5,85	250	300	X 1 U 31 61 B B B A	X 1 U 31 62 B B B A
XV-1U/6.5	6,50	250	300	X 1 U 32 61 B B B A	X 1 U 32 62 B B B A
XV-1U/7.8	7,54	220	260	X 1 U 34 61 B B B A	X 1 U 34 62 B B B A
XV-1U/9.8	9,88	190	230	X 1 U 36 61 B B B A	X 1 U 36 62 B B B A

P1) Max. working pressure - P3) Max. peak pressure

For heavy-duty applications, it is recommended to check the admissible torque of the shaft

Dimensions table

TYPE	Weight kg	A	B	C	D	D
		mm	mm	mm	IN	OUT
XV-1U/0.9	1,000	82,6	41,8	70,6	3/8" BSPP	3/8" BSPP
XV-1U/1.2	1,020	83,5	42,3	71,5	3/8" BSPP	3/8" BSPP
XV-1U/1.7	1,060	85,0	43,0	73,0	3/8" BSPP	3/8" BSPP
XV-1U/2.2	1,080	87,0	44,0	75,0	3/8" BSPP	3/8" BSPP
XV-1U/2.6	1,110	89,0	45,0	77,0	3/8" BSPP	3/8" BSPP
XV-1U/3.2	1,140	91,0	46,0	79,0	3/8" BSPP	3/8" BSPP
XV-1U/3.8	1,170	93,0	47,0	81,0	3/8" BSPP	3/8" BSPP
XV-1U/4.3	1,220	95,0	48,0	83,0	3/8" BSPP	3/8" BSPP
XV-1U/4.9	1,250	98,0	49,5	86,0	3/8" BSPP	3/8" BSPP
XV-1U/5.9	1,310	101,5	51,3	89,5	3/8" BSPP	3/8" BSPP
XV-1U/6.5	1,350	105,0	52,5	93,0	3/8" BSPP	3/8" BSPP
XV-1U/7.8	1,410	108,0	54,5	96,0	3/8" BSPP	3/8" BSPP
XV-1U/9.8	1,550	117,0	59,0	105,0	3/8" BSPP	3/8" BSPP

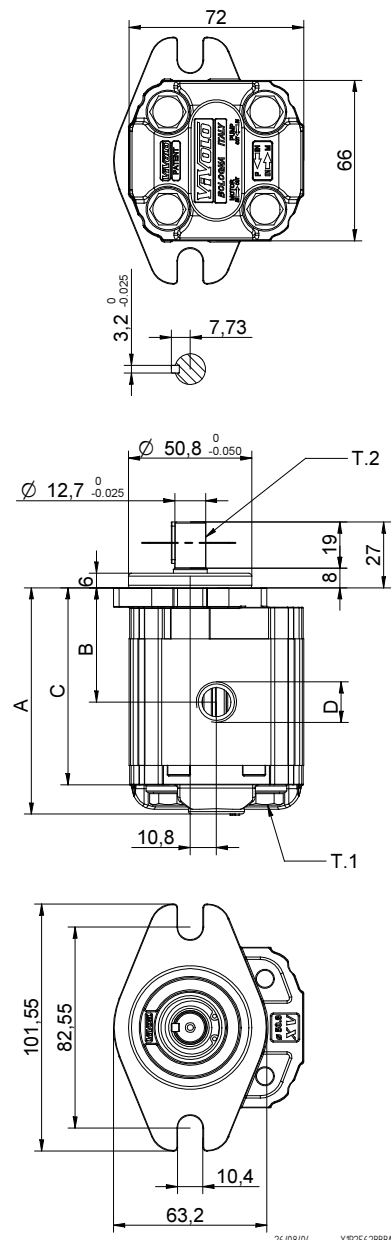

T.1 = 24.5÷29.4 [Nm] - screw tightening torque M8

T.2 = 32.8 [Nm] - admissible shaft torque (N.B. When choosing a shaft, always check the admissible torque).

Table of variations

XV-1U

ø50.8 FLANGE "SAE AA"

ø50.8 FLANGE "SAE AA"		Shaft		Cover	
Left rotation	Right rotation			Left rotation	Right rotation
		CI001 - Parallel T.2 = 25.8 [Nm] 	CI002 - Parallel T.2 = 32.8 [Nm] SAE 		
61	62	A	B	A	A
		CF003 - Milled shank T.2 = 25.9 [Nm] SAE 	CO002 - Tapered T.2 = 119.8 [Nm] 		
		E	G	B	B
		SAE 	SCF05 - Splined T.2 = 32.2 [Nm] SAE J 498 9T 20/40 DP 		
		I	K	C	C
		CO002+HK - Tapered T.2 = 119.8 [Nm] HK 14-12 	CI001+HK - Parallel T.2 = 25.8 [Nm] HK 14-12 		
		O	P	D	D
				N	N
				O	O

Displacement	
TYPE	CODE
XV-1U/0.9	16
XV-1U/1.2	17
XV-1U/1.7	18
XV-1U/2.2	20
XV-1U/2.6	21
XV-1U/3.2	23
XV-1U/3.8	25
XV-1U/4.3	27
XV-1U/4.9	29
XV-1U/5.9	31
XV-1U/6.5	32
XV-1U/7.8	34
XV-1U/9.8	36

Standard bodies							
Displacement cm3/rev	Standard threads						
	0.9	I - I	B - B	J - J	B - Z	Z - Z	G - F
1.2	I - I	B - B	J - J	B - Z	Z - Z	G - F	
1.7	I - I	B - B	J - J	B - Z	Z - Z	G - F	
2.2	I - I	B - B	J - J	B - Z	Z - Z	G - F	
2.6	I - I	B - B	J - J	B - Z	Z - Z	G - F	
3.2	I - I	B - B	J - J	B - Z	Z - Z	G - F	
3.8	I - I	B - B	J - J	B - Z	Z - Z	G - F	
4.3	I - I	B - B	J - J	B - Z	Z - Z	G - F	
4.9	I - I	B - B	J - J	B - Z	Z - Z	G - F	
5.9	I - I	B - B	J - J	B - Z	Z - Z	G - F	
6.5	I - I	B - B	J - J	B - Z	Z - Z	G - F	
7.8	I - I	B - B	J - J	B - Z	Z - Z	G - F	
9.8	I - I	B - B	J - J	B - Z	Z - Z	G - F	

Table showing standard flange and thread combinations available in stock

Body (threads/flanges)							
	A		B		C		D
	E		F		G		
	H		I		J		Z
					Closed Body		